

1. OVERVIEW

The following picture shows the assignment of the individual connection areas on the bottom of the inverter.

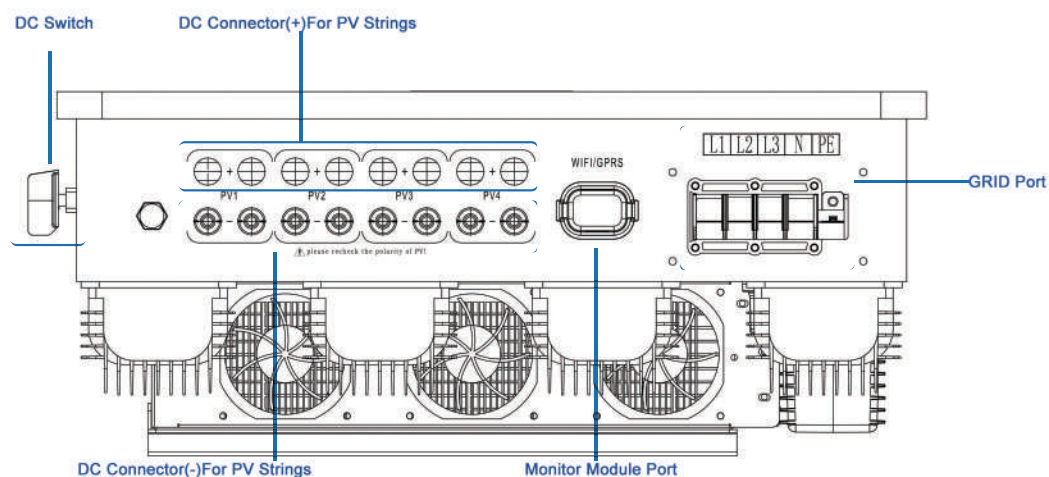

2. PACKAGE LIST

On receiving the inverter, please check to make sure the packing and all components are not missing or damaged. Please contact your dealer directly for supports if there is any damage or missing components.

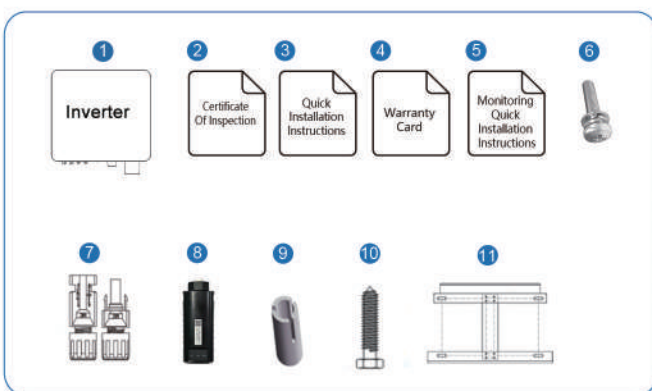

No.	Qty	Items	No.	Qty	Items
1	1	Inverter	11	1	Wall Mounting Bracket
2	1	Certificate Of Inspection			
3	1	Quick Installation Instructions			
4	1	Warranty Card			
5	1	Monitoring Quick Installation Instructions			
6	4	Screw			
7	2/3/4	DC Connector			
8	1	Monitor Module			
9	3/4	Expansion Tube			
10	3/4	Mounting Bracket Screw			

3. QUICK INSTALLATION

A

Mounting

40-50K

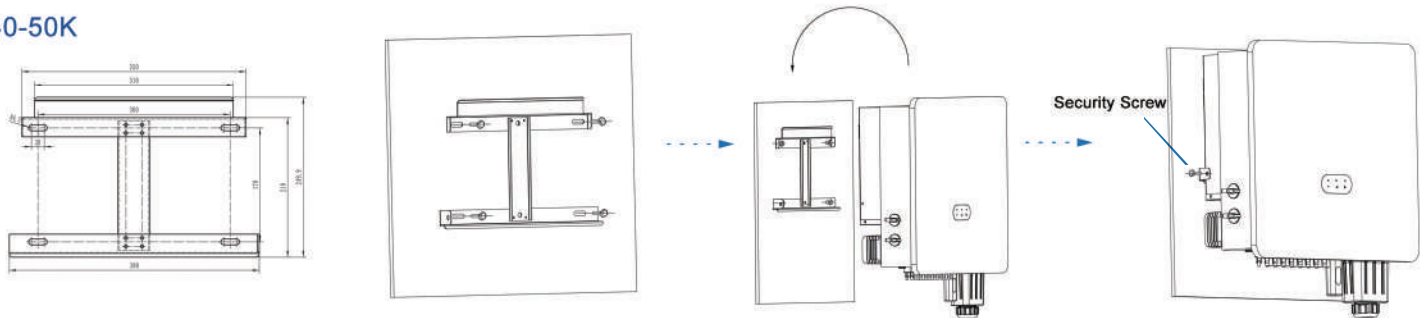

B

PV Connection

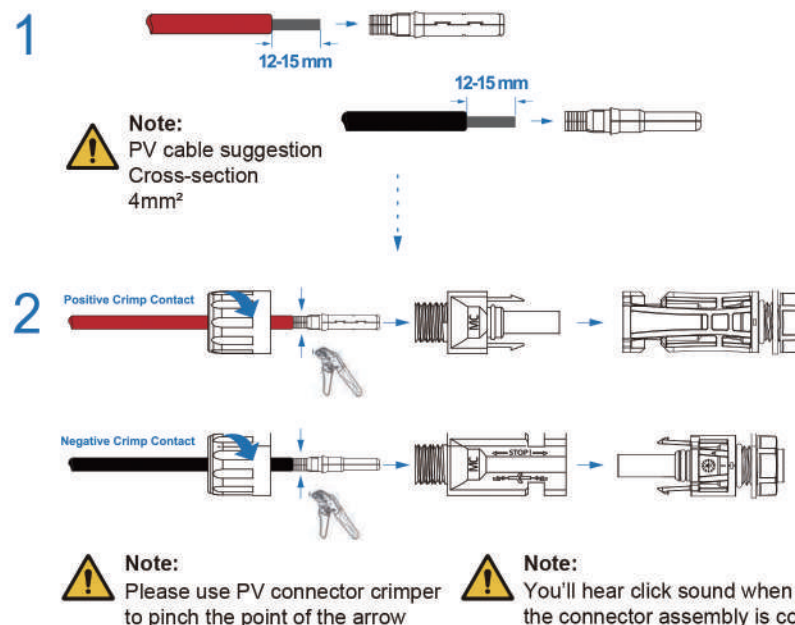

3

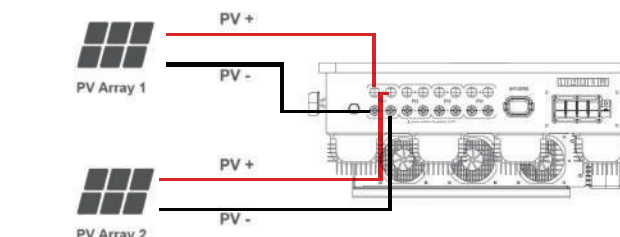

Warning: The fatal high voltage may on the DC side, please comply with electric safety when connecting. Please make sure the correct polarity of the cable connected with inverter, otherwise inverter could be damaged.

C

AC Connection

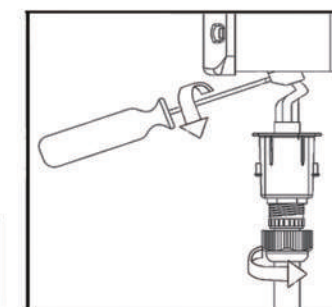
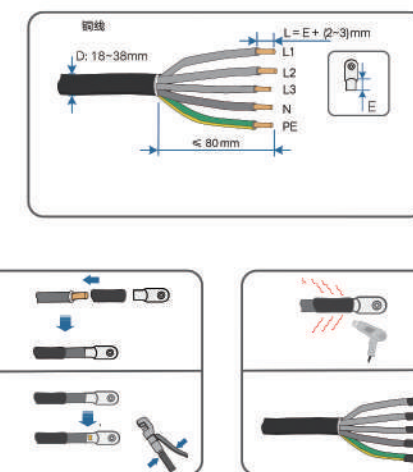

1. Turn off the AC side circuit breaker and place a "no power-on" sign to prevent it from being switched on.
2. Connect the AC side connector to the corresponding AC terminal at the bottom of the inverter.
3. Connect the "PE" cable to the ground.
4. Connect the live and neutral wires to the AC circuit breaker.
5. Connect the other end of the AC circuit breaker to the grid.
6. Check that all cables are firmly connected.

D

Earth Connection

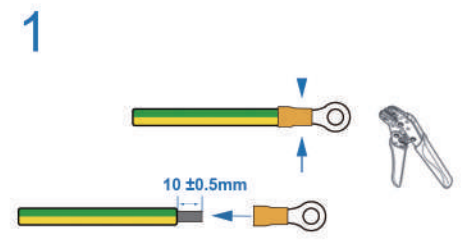

Note:
Earth cable PE suggestion:
Cross-section (Copper) 4-6mm² / 10AWG

2 Fix the grounding screw to the grounding connection of the machine housing.

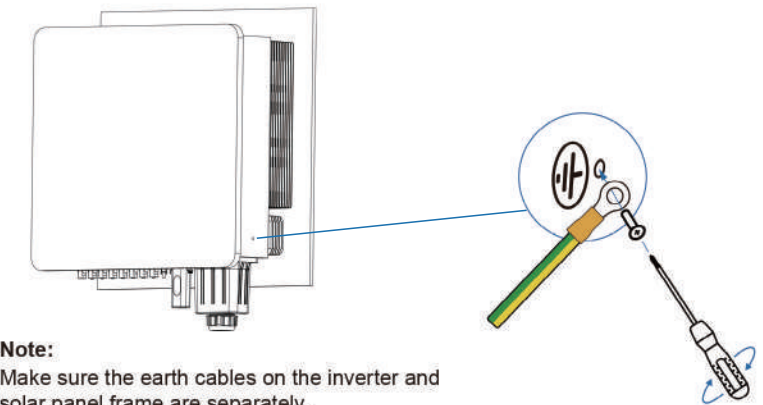

Note:
Make sure the earth cables on the inverter and solar panel frame are separately.

E

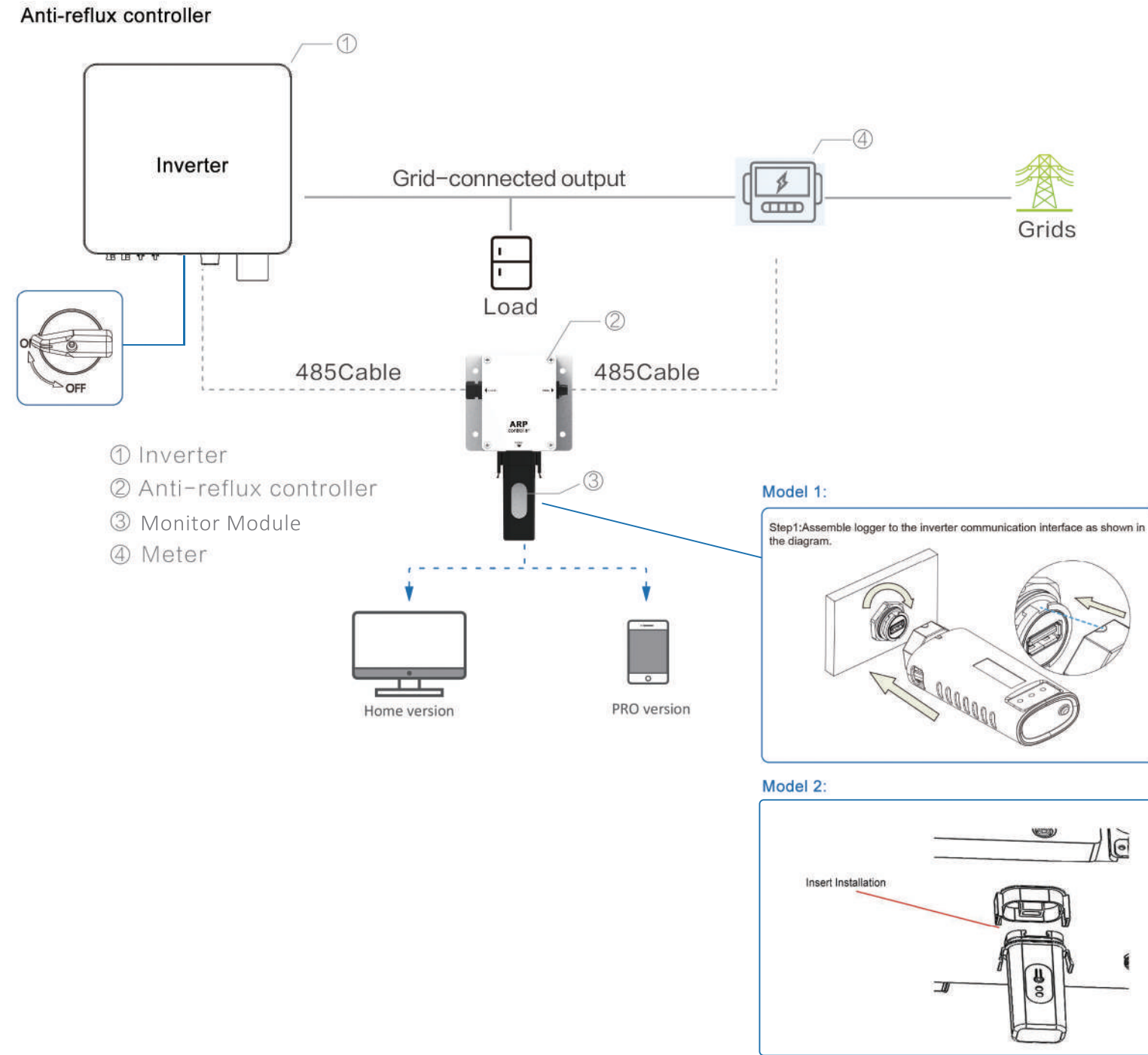

- ① Inverter
- ② Anti-reflux controller
- ③ Monitor Module
- ④ Meter

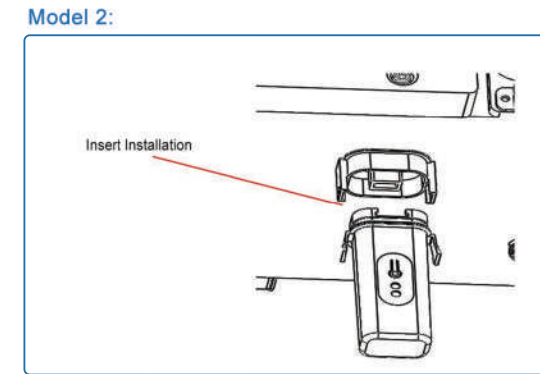
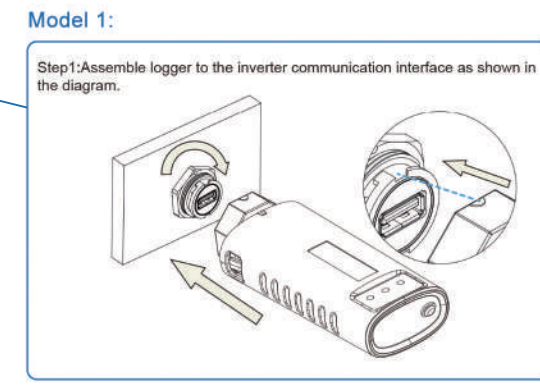

Configure the Monitor Module, router, account registration, etc. Please check the WiFi connection manual for details.