

# AU Series

## Grid-tied PV Inverter user manual



### AU 3~10K1P

The logo for Austa, featuring the word "Austa" in a bold, sans-serif font with a yellow swoosh underneath.

## NINGBO AUSTA SOLAR TECH CO.,LTD.



Thank you for choosing AUST on-grid PV inverter. In order to ensure your safety and proper use, please read the manual in details before using. Thanks for your cooperation!

# Contents

- 1. Overview ..... 1
  - 1.1 Use of this manual ..... 1
  - 1.2 Symbols ..... 1
  - 1.3 Nameplate ..... 2
- 2. Delivery ..... 3
  - 2.1 Scope of Supply ..... 3
  - 2.2 Product Acceptance ..... 3
- 3. Description ..... 4
  - 3.1. Brief Introductions ..... 4
  - 3.2 General Introduction ..... 5
- 4. Installation ..... 7
  - 4.1 Installation Procedure ..... 7
  - 4.2 Installation Preparation ..... 7
  - 4.3 Mechanical Installation ..... 11
  - 4.4 Electrical Connection ..... 13
- 4. Monitoring ..... 21
  - 5.1 Overview ..... 21
  - 5.2 Austa Solar Monitor ..... 23
- 6. Trial run ..... 24
  - 6.1 Inspection before trial run ..... 24
  - 6.2 Test run steps ..... 24
- 7. Shut down & Dismantle ..... 25
  - 7.1 Shut down ..... 25
  - 7.2 Dismantle the inverter ..... 25
  - 7.3 Discarding the inverter ..... 25
- 8. Operating ..... 26
  - 8.1 Working Mode ..... 26
  - 8.2 Startup mode ..... 27
  - 8.3 Power generation process ..... 32
  - 8.4 Disconnect from grid ..... 32
- 9. Maintenance ..... 33
  - 9.1 Maintenance ..... 33
  - 9.2 Troubleshooting ..... 33
  - 9.3 Quality Assurance ..... 35

10.Specification.....	36
10.1 Specification.....	36
10.2 Quality guarantee .....	37

# 1

## Overview

### 1.1 Use of this manual

This manual mainly introduces installation, operating and maintenance of inverter and related technical parameters. It is suitable for people who install the inverters and do other related jobs. Readers need to have some knowledge of electric, electrical wiring and mechanics. Before installing this product, please read this manual carefully, and put it in a suitable place, so as to ensure that relevant personnel of installation and operation can easily get it.

This manual applies to the following types of PV inverters

AU3/4/5/6/8/10K1P Series

### 1.2 Symbols

Please strictly follow below safety rules when installing and operating.



#### **DANGEROUS**

**DANGEROUS** indicates a hazard with a high level of risk which, if not avoided, will result in death or serious injury.



#### **WARNING**

**WARNING** indicates a hazard with a medium level of risk which, if not avoided, could result in death or serious injury



#### **CAUTION**

**CAUTION** indicates a hazard with a low level of risk which, if not avoided, could result in minor or moderate injury.





#### **NOTE**

**NOTE** indicates a situation which, if not avoided, could result in equipment or property damage.

### 1.3 Nameplate

Take AU5K1P for example

<b>Grid Tie Solar Inverter</b> NINGBO AUSTA SOLAR TECH CO.,LTD. 1-1 NO.136 Haichuan Road Jiangbei District Ningbo Zhejiang P.R. China			
<b>AU5K1P</b>		<b>NO.</b>	
V <sub>max</sub> PV	550V	AC voltage	1φ/N/PE230Vac
I <sub>sc</sub> PV	20A/20A	Frequency	50Hz
MPPT voltage range	80-550Vdc	Max. continuous current	25A
Maximum PV input current/ MPPT	15A/15A	Max. continuous Power	5.5kW
PF	1(0.8Leading-0.8Lagging)	Max. AC apparentPower	5.5kVA
Protective class	Class I		
Ingress protection	IP 66		
Working temperature	-25℃-60℃(Derating 45℃)		
Overvoltage category	OVC II(PV)	OVCIII(AC)	
			
			

# 2

## Delivery

### 2.1 Scope of Supply

There are following items in the packing box, as shown in Table 2-1.

Please check in time after receiving the products.

NO.	Name	Qty	Note
1	PV on-grid inverter	1	
2	Product qualification certificate	1	
3	Fixed bracket	1	
4	Factory inspection report	1	
5	PV cable connector	2	Male/female cable connector: 2 for each
6	Cross recessed hex bolt	2	Used for fastening machine and the fixed plate
7	Expansion bolt	3	Used for fastening the fixed plate
8	Hexagon bolt	3	Used for fastening the fixed plate
9	Flat washer	3	Used for fastening the fixed plate
10	Spring washer	3	Used for fastening the fixed plate

Table 2-1: Scope of supply

### 2.2 Product Acceptance

Although we have carefully tested and inspected the products before delivery, but there might be damages during transport. So, please check them when sign for them. If there is any damage, please contact the shipping company or directly contact AUSTA. Please provide photos of the damaged parts, and we will provide the best service as fast as possible.

## 3.

### 3.1. Brief Introductions

On-grid PV power generation system usually is composed of solar panels, junction box, inverter, ammeter and power grid. The core of the system is PV grid-connected inverter. The sunshine irradiates on the surface of the solar panels, solar panels output DC, converted by inverter, then output AC of the same frequency and phase with the grid, and then feed into the grid.

TLC series in application of PV power generation system is shown in Figure 3-1.

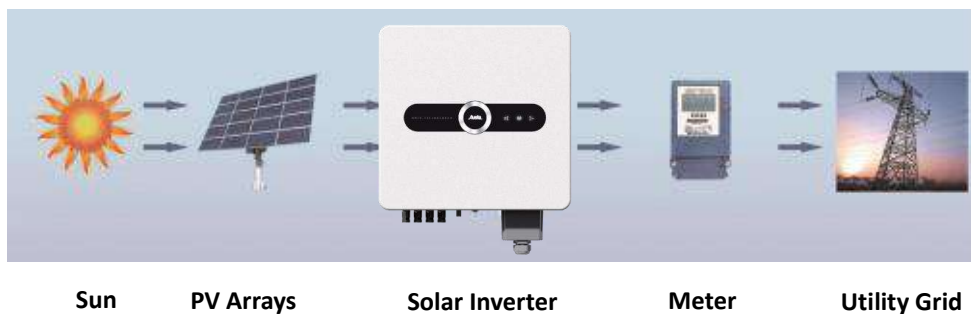

Fig 3-1 Grid-connected PV Power Generation System

#### Product performance

- Transformerless, highest efficiency is 98.1%
- Wide input voltage, MPPT efficiency is 99.9%
- Two way independent MPPT control to deal with different installation angles, enhance power generation
- Active and passive anti-islanding protection technology
- Comprehensive protection, higher reliability
- IP65 Outdoor design, suitable for harsh environment
- RS485,WIFI,GPRS multi-communication interface, user friendly.



### 3.2 General Introduction

✧ Appearance and interface

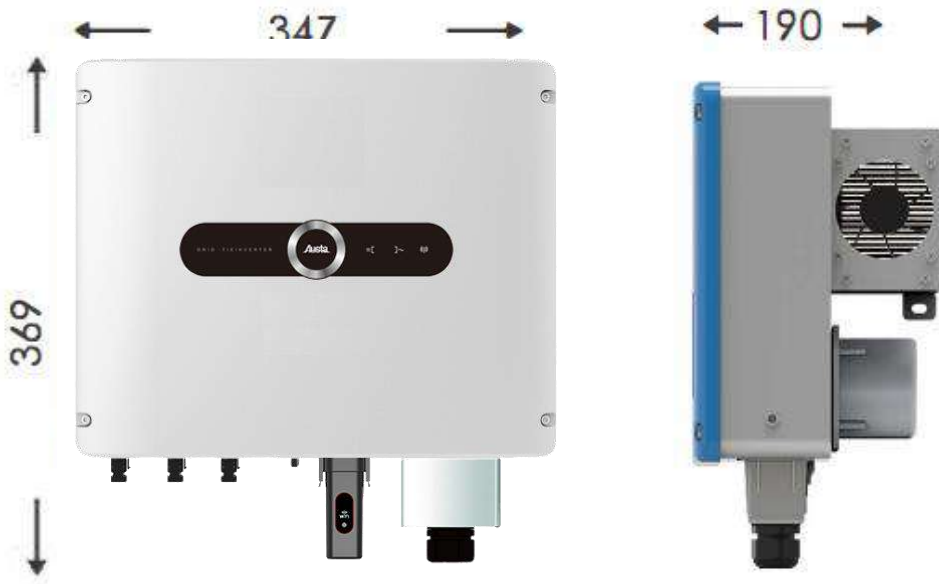

Fig 3-2 Appearance of AU-10K1P

Appearance of AU3-10KTLD (take AU10K1P for example) is as shown in Figure 3-2. Its external interface is in the bottom of the machine and is composed of PV input port +, PV input port-, communication port, DC switch, AC output. Please refer to Figure 3-5 and Table 3-1 for details.

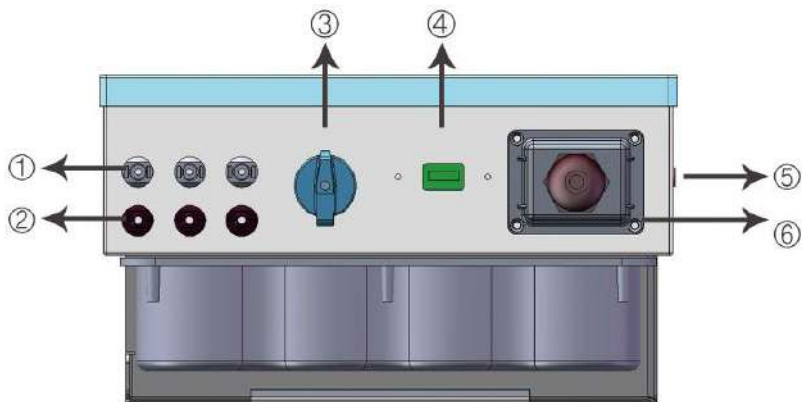

Fig 3-3: External Port

No.	Name	Description
1	PV input port +	Inverter's DC input port, connect with + port of PV arrays
2	PV input port -	Inverter's DC input port, connect with - port of PV arrays
3	DC switch	Electric cut off between inverter and PV arrays
4	WIFI/GPRS/RS485	Connect inverter with PC through this port for remote monitoring
5	Earthing bolt	Connect machine case with ground
6	AC output port	Connect with phase L and wire N of the grid through the breaker, connect ground wire to the ground

Table 3-1: External Interface

# 4

## Installation

Please carefully read below installation guide for AU3-10K1P.

### 4.1 Installation Procedure

Before installing and operating this product, please strictly abide by the installation sequence and warning symbols.

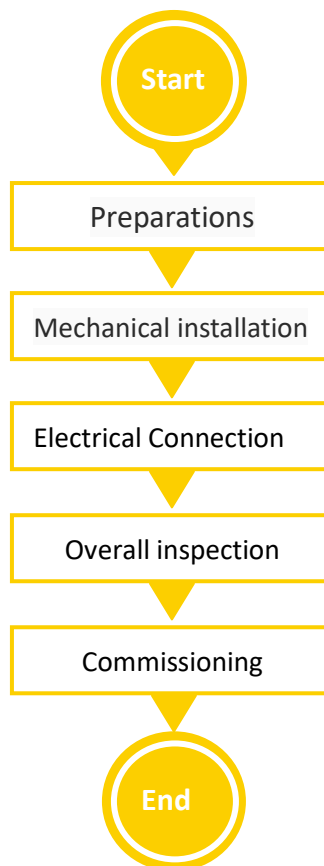

Fig 4-1 Installation procedure

### 4.2 Installation Preparation

#### ● Check whether there is damage during transport

Although we have carefully tested and inspected the inverter before shipping, there might be damage during transport. So please check them before installation. If there is any damage, please contact the

shipping company or directly contact us. Please provide photos of the damaged part. We will provide the best service at fast as possible.

● **Tools for installation**

The following installation tools and parts are needed.

- ✓ Spanner
- ✓ Electric impact drill
- ✓ Cross screwdriver
- ✓ M4 Allen wrench
- ✓ Megameter & Multimeter

● **Choose installation location**



**WARNING**

Please read carefully and follow the following basic installation requirements. Failure to follow these warnings will directly lead to serious personal injury or even life-threatening.



**WARNING**

Poor ventilation in the installation environment will affect system performance. It is necessary to ensure good ventilation during the operation of the equipment. The device must be kept upright and the heat sink is not blocked to ensure adequate cooling inside the device.

The inverter protection level reaches IP65 and can be used for indoor or outdoor installation.

Choosing the best installation location for the inverter plays a very important role in its safe operation, life guarantee, and performance guarantee.

- 1 Ensure that the installation wall has the capacity to support the inverter for a long time.
2. The inverter should be installed in a location that is easy for electrical connection, operation and maintenance.
3. The installation wall must have fireproof performance, and there must be no flammable materials or flammable gas in the installation space.



4. Do not install the inverter in the living area to avoid noise affecting daily life.
5. The installation location of the inverter should be far away from the reach of children.
6. Installation height is better to make the LCD at the same level with people's eye so as to make it convenient to operate on the LCD.

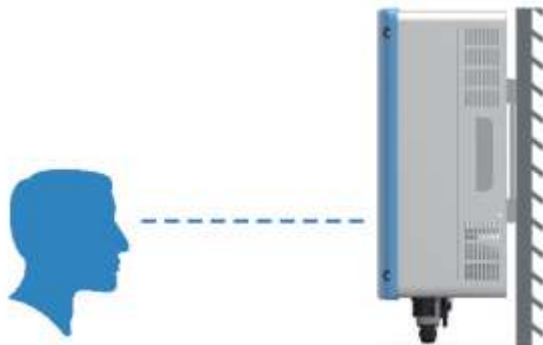

7. The inverter needs to be installed uprightly, and cannot be placed horizontally or upside down, or tilted.

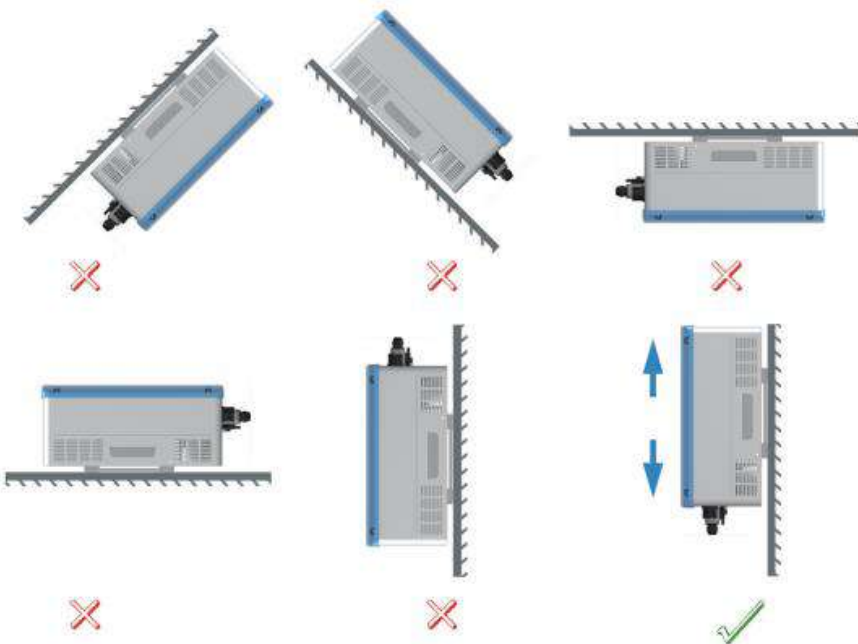

8. The temperature range of the installation environment should be between  $-25^{\circ}\text{C}$  and  $60^{\circ}\text{C}$ , relative humidity.  $\sim 95\%$  (When the ambient temperature exceeds  $45^{\circ}\text{C}$ , the output power of the inverter will decrease).

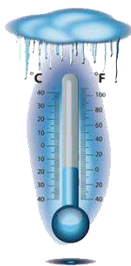

Minimum ambient temperature  $-25^{\circ}\text{C}$



Maximum ambient temperature  $60^{\circ}\text{C}$



Environmental humidity: 0-95% non-condensing

9. Enough space surrounding the inverter is needed to ensure good heat dissipation.

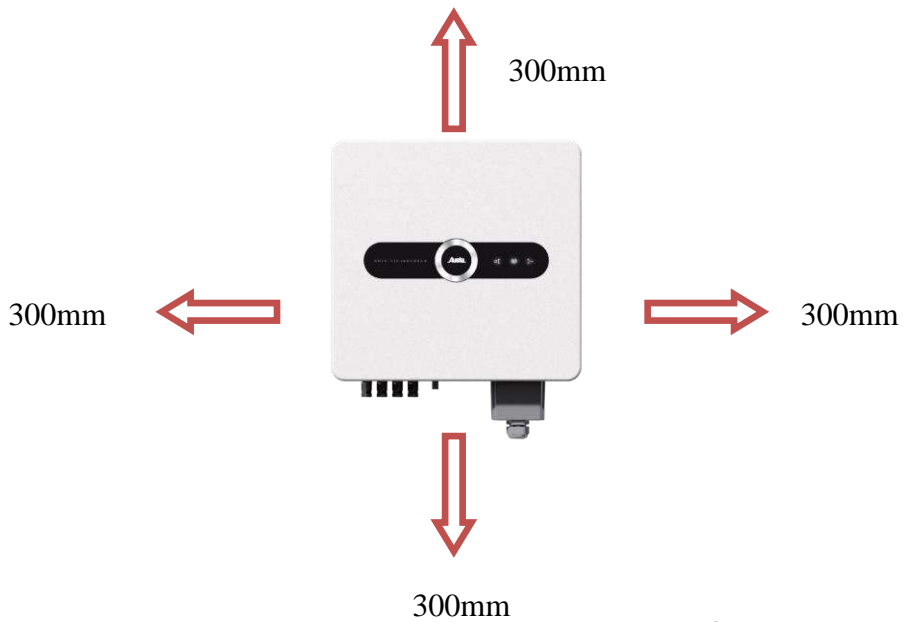

10. Ensure that the inverter is ventilated and dissipated smoothly. It is strictly forbidden to install the inverter in a closed space, otherwise the inverter will not work normally, and there may even be a danger of explosion.

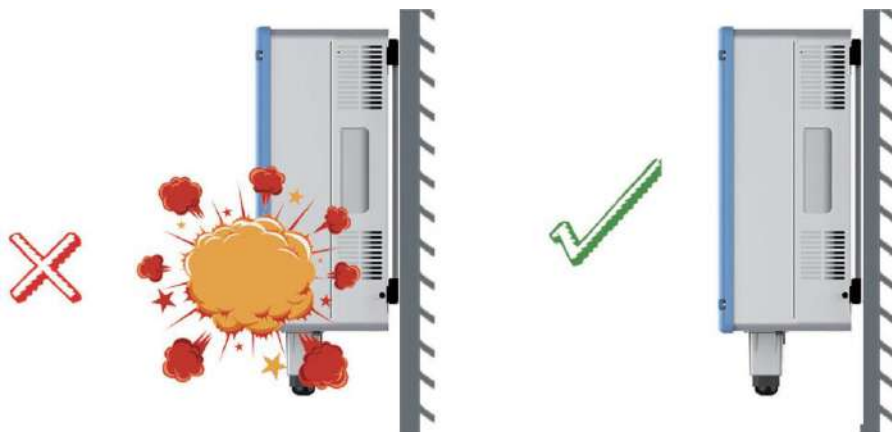

11. Multiple inverters can be installed side by side, and multiple rows of inverters need to be installed staggered to facilitate heat dissipation.

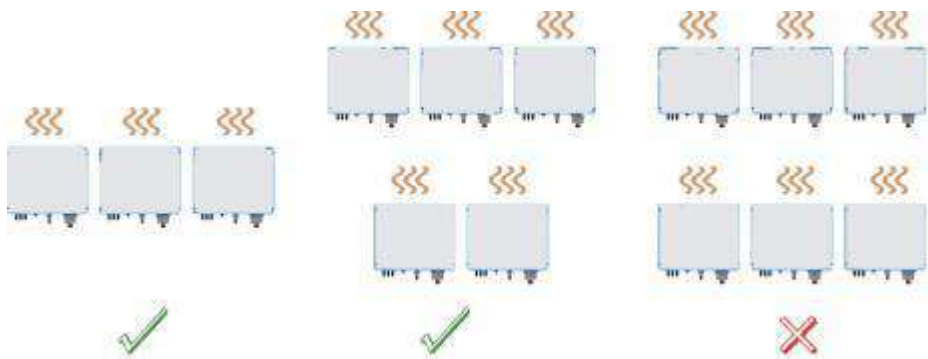

12. Please choose a place where you can avoid rain, snow, and direct sunlight for installation (sunlight, rain,

snow, etc. will directly affect the service life of the inverter. If it is unavoidable, please shield the inverter reasonably. To ensure the best operating environment)



### 4.3 Mechanical Installation

After moving the inverter to the installation site, install the fixing bracket to the wall through the expansion bolt (expansion bolt is M8×30) assembly, and then install the inverter to the fixing bracket.

Installation:

1. Place the fixed bracket on the wall at a suitable height and position. Mark the drilling position according to the fixed bracket specification.

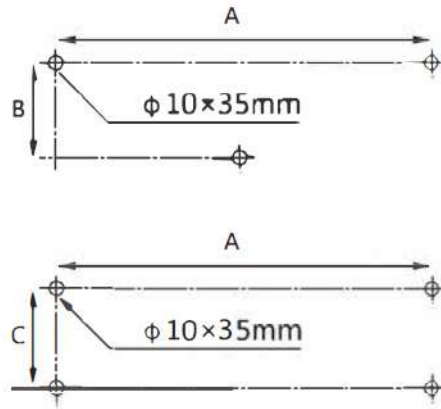

4-2 Installation size

Type	A(mm)	B(mm)	C(mm)
AU3/4/5/6K1P	167	/	90
AU8/10K1P	200	21	/

## 2. Drill holes and install fixed brackets

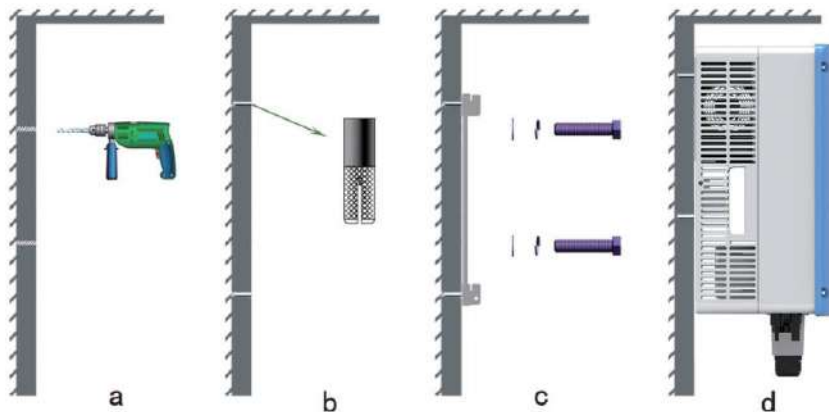

4-3 installation steps

If install the inverter on concrete wall

- Mark the drilling position on the wall according to the specifications of the fixing plate in Figure 4-2, and then drill at the marked position. A circular hole with a diameter of 10mm and a depth of 35mm.
- Insert the expansion coil of M8×30 into the round hole.
- Align the mounting holes of the fixing plate with the expansion solenoids and fix them with hexagonal bolts.
- Hang the inverter on the fixed bracket.

If install on metal scaffolds

Similar to drilling holes on the wall, drill holes according to the specifications of the fixing plate, fix the fixing plate with MS bolts, and hang the chassis on the fixing plate.



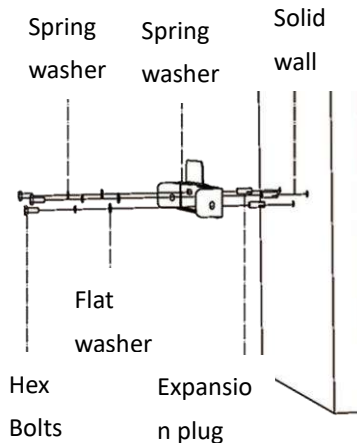

**Note:** Please cooperate with the machine before installing the fixed bracket to prevent reverse installation.

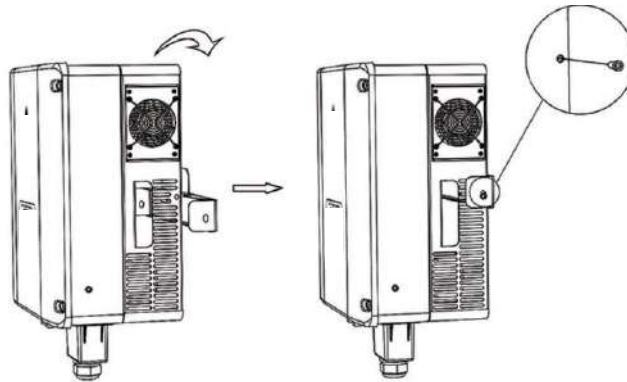

The inverter must be wall-mounted vertically

#### 4.4 Electrical Connection

When performing electrical wiring work, personal protective equipment must be worn.



#### **DANGEROUS**

**High voltage! Electrical shock!**

**Pay attention to safety before making electrical connections. Exposing photovoltaic strings to sunlight will generate dangerous high voltages.**

**Before making electrical connections, make sure that all cables are not live. Do not turn on the AC circuit breaker before completing the electrical connections.**



#### **WARNING**

**Any improper operation during the wiring process may cause equipment damage or personal injury or death.**

**The wiring operation must and only allow professional and technical personnel to complete. The cables used in the photovoltaic power generation system must be firmly connected, intact, well insulated, and have the correct specifications.**



## NOTE

The relevant rules of the local power grid and the relevant safety instructions of the photovoltaic string must be followed.

All electrical installations must comply with the electrical standards of the country/region where the installation is located.

Only after getting permission from the local power supply department, can the inverter be integrated into the grid.

### 4.4.1 Terminal introduction

The external wiring terminal is located at the bottom of the inverter, as shown in the figure below:

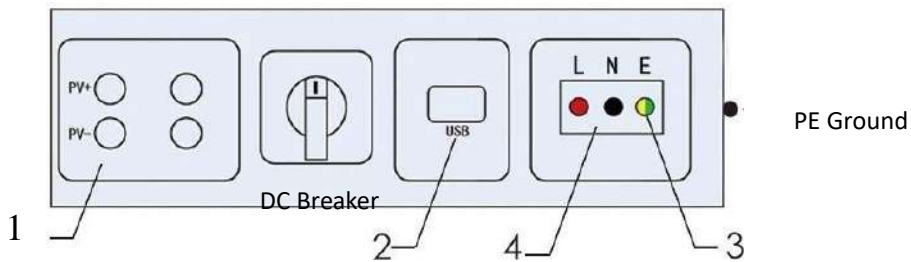

No.	Terminal	Description
1	PV input terminal	Inverter's DC input port, connect to solar panels.
2	RS485 interface	Used to connect to WiFi module or GPRS data acquisition module
3	PE terminal	For reliable grounding of the inverter
4	AC output terminal	Connect to the grid through the AC terminal

### 4.4.2 Wire Connection

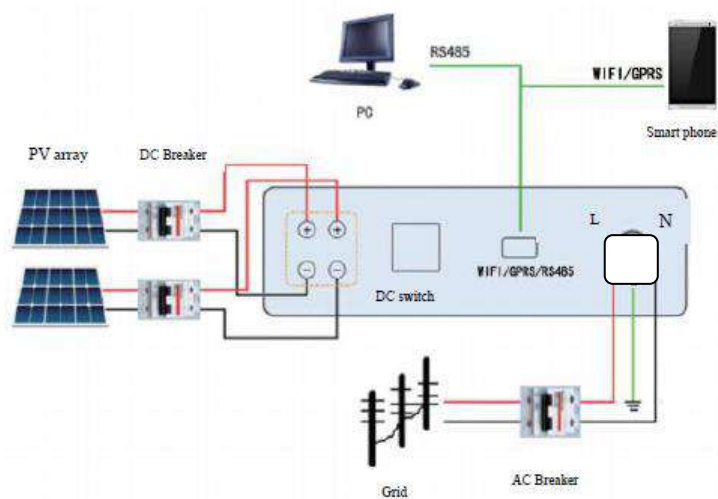

In the figure, the L1 phase of the power grid is represented by a yellow line, the L2 phase is represented by a green line, the L3 phase is represented by a red line, and the power grid N line is represented by a black line. It can be adaptive, and the N line can be omitted.) The protective grounding line is represented by a yellow-green line. It must be ensured that the inverter shell is reliably grounded.

#### 4.4.3 AC Wiring



### NOTE

The inverter can be connected to the grid only if the local power company or the competent authority has obtained the access permission. Before connecting to the grid, make sure that the grid voltage and frequency meet the requirements of the inverter.

#### ● AC Circuit Breaker

An independent three-level or four-level circuit breaker on the AC side of each inverter can ensure that the inverter is safely disconnected from the grid.

No.	Inverter model	Breaker model
1	AU4/5/6K1P	15A
2	AU8/10K1P	30A



### NOTE

Multiple inverters cannot share one circuit breaker

No load can be connected between the inverter and the circuit breaker

#### ● Leakage protector

There is an integrated leakage current detection unit inside the inverter. When the inverter detects a leakage current greater than the allowable value, it will quickly disconnect from the grid.

#### ● Parallel requirements for multiple inverters

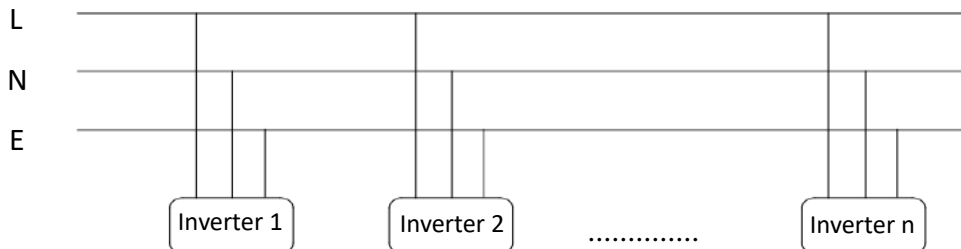

### DANGEROUS

High voltage! Electrical shock!

Before electrical operation, make sure that all cables are not live.

Do not turn on the AC circuit breaker before the electrical connection of the inverter is completed

● AC cable wiring steps

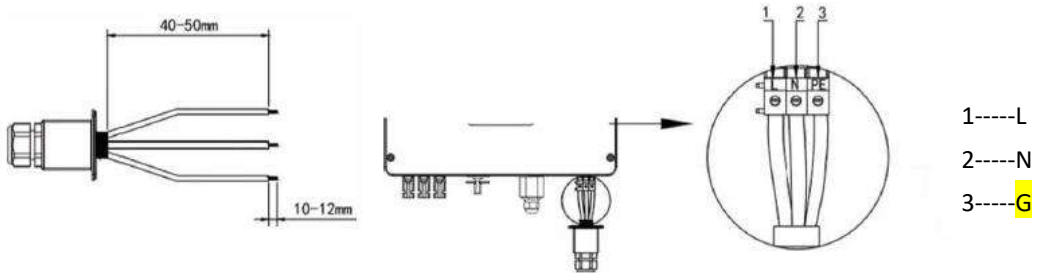

1. Turn off the AC side circuit breaker and place a "no power-on" sign to prevent it from being switched on.
2. Connect the AC side connector to the corresponding AC terminal at the bottom of the inverter.
3. Connect the "PE" cable to the ground.
4. Connect the live and neutral wires to the AC circuit breaker.
5. Connect the other end of the AC circuit breaker to the grid.
6. Check that all cables are firmly connected.
7. After fixing the AC cover, tighten the waterproof plug.



**NOTE**

1. Flexible copper cable is the best choice for AC side cable.
2. The grounding wire must be connected and well grounded.

Model	Distance between inverter and grid connecting point, corresponsive cable(cable diameter: mm 2 )			
	10-30m	30-50m	50-80m	Above 80m
AU3K1P	4	4	6	When there is only one inverter in the project, try to avoid distance between inverter and grid connecting point more than 80m. When there are multiple inverters in project, it can firstly use combiner box to combine outputs of inverters, then choose cable with bigger diameter.
AU4/5/6K1P	6	8	10	
AU8K1P	10	16	25	
AU10K1P	16	16	25	

4.4.4 PV array connection



**DANGEROUS**

voltage! Electrical shock!

Pay attention to safety before electrical connection. Exposure of PV array to sunlight will generate dangerous voltage.



## WARNING

Before connecting the PV array to the inverter, ensure that the PV array is well insulated to the ground.

### ● PV array input configuration

The inverter has two PV array input areas PV1 and PV2, and the inverter is equipped with an MPPT tracker for each input area.



## NOTE

The following two precautions must be met, otherwise, the damage to the inverter will be without the scope of the warranty.

- When designing a PV array, be sure to ensure that the voltage of each PV array is lower than 550V even at the lowest temperature, otherwise it will cause irreversible damage to the inverter.
- Ensure that the maximum short-circuit current on the DC side is within the allowable range of the inverter, otherwise it may cause irreversible damage to the inverter.

The two PV string inputs operate independently, and each has an independent MPPT. Therefore, the two photovoltaic inputs can be different from each other, including: different panel types; different numbers of cells in the PV string; different inclination angles, different azimuth angles.



## NOTE

In order to make full use of the DC input power, the PV strings of the same input should be close to the same (especially the voltage), including: the same model; the same number of panels; the same inclination angle; the same azimuth angle.

### ● PV array input connection

The PV input needs to be connected with plug-in PV input terminals, and plug-in terminals for quick connection to the PV input are provided in the scope of supply.

The DC cables on the PV string side need to be installed with DC connectors. The connector is already provided in the scope of supply.



## NOTE

In order to ensure that the inverter reaches the IP65 protection level, only use the supplied connector or products with the same protection level.

### ● DC cable

## DC cable requirements

Cross-sectional area	Cable outer diameter	Maximum withstand voltage	Maximum input current of each string
2.5~6mm <sup>2</sup>	6-9mm <sup>2</sup>	1100V	15A



### NOTE

The maximum designed current of each DC terminal is not more than 15A

### ● DC cable connection steps



### DANGEROUS

**High voltage! Electrical shock!**

**There may be high voltage in the inverter!**

**Before electrical operation, make sure that all cables are not live.**

**Before the electrical connection of the inverter is completed, the AC circuit breaker switch shall not be installed.**

1. This series of connectors only supports multi-strand copper wires. Cut and strip as required, the stripping length is 7-8mm.

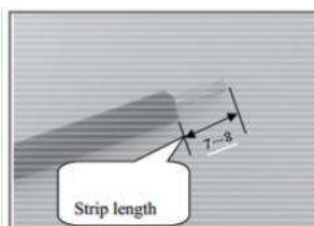

2. Crimp the wire. Place the terminal correctly in the terminal crimping pliers, then put the bare copper wire part of the cable into the terminal opening slot and press it firmly. Be careful not to damage the terminals and the copper wires of the wires.

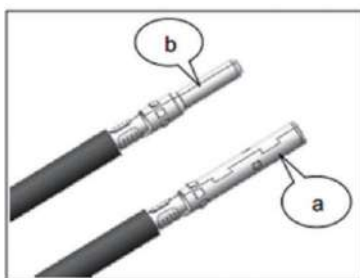

a-female terminal    b-male terminal

3. Insert the terminals into the main body of the plastic case. Correctly insert the corresponding plastic case according to the positive and negative polarity. You can gently pull the wire in the reverse direction to

verify whether the connection is firm.

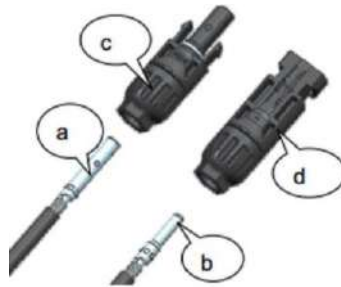

a-female terminal    b-male terminal  
c-male housing body    b-female housing body



### WARNING

When wiring the PV cable, the positive and negative poles must be connected correctly. Please cut off the power of the system and verify whether the male and female connectors are of the same model before use.

4. After the cable is plugged in, use a special wrench or adjustable wrench to tighten the nut. In order to achieve better results, two wrenches can be used to work together.

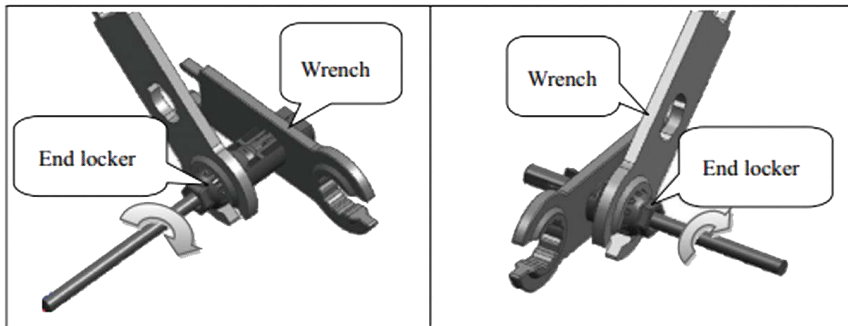

5. Connect the male head and the female head, align the buckle on the male head with the groove on the female head and insert, there will be a crisp sound when connected.



### WARNING

Since the inverter is a transformer less type, it is required that the positive and negative poles of the photovoltaic string cannot be grounded, otherwise the inverter will not operate normally.



## WARNING

1. The maximum DC input voltage of the two sets of PV arrays connected to MPP Tracker A and MPP Tracker B must be less than 550V, and the MPP working voltage must be between 80V and 550V. The specifications and installation methods of the two sets of PV arrays may be inconsistent.
2. When two sets of PV arrays connected to MPP Tracker A (MPP Tracker B) are connected in parallel, the specifications and installation methods of the two sets of PV arrays must be consistent, otherwise the power generation of the PV system will be affected! If the voltage difference between the two sets of PV arrays is greater than 5%, an arc may occur when the battery panels are plugged in and out, which will burn out the PV plug and even cause personal injury.

### Grounding system

In this PV power generation system, all non-current-carrying metal parts and equipment housings should be grounded (such as the bracket of the PV arrays, the inverter housing, etc.).

A single inverter system needs to ground the "PE" cable.

Multiple inverter systems support multi-point grounding, but all inverter "PE" cables and the grounding points of the metal frame of the PV array need to be connected to the equipotential line (depending on site conditions) to achieve equipotential connection .

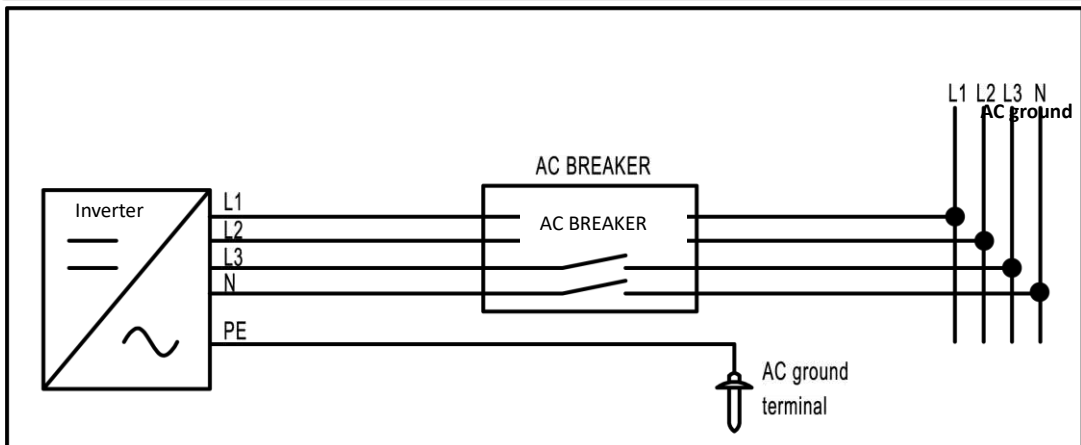
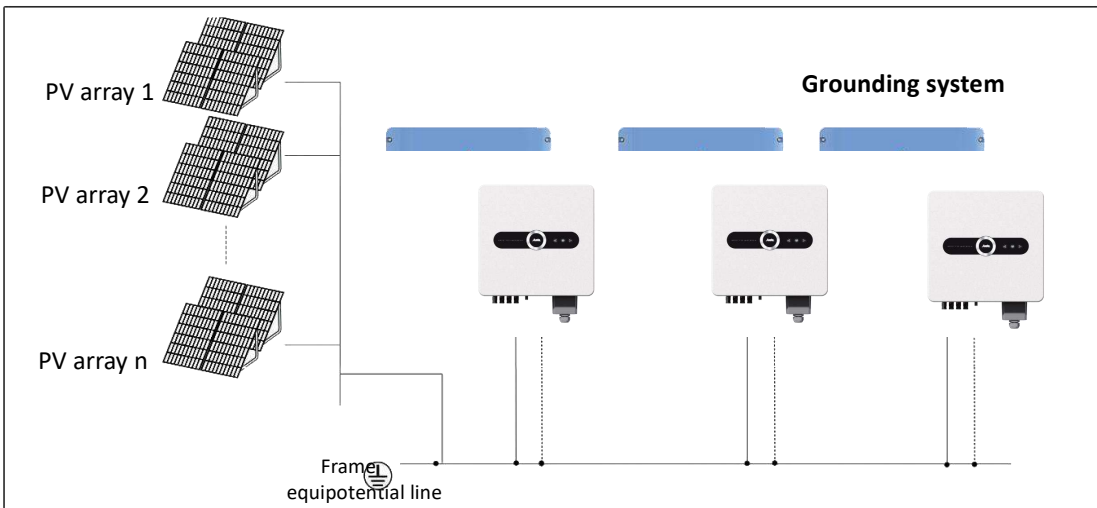



# 5 Monitoring

5.

## 5.1 Overview

The inverter has a variety of communication methods. When users need to monitor the operation information of the photovoltaic power generation system, we provide the communication system solutions shown in Figures 5-1 and 5-2.

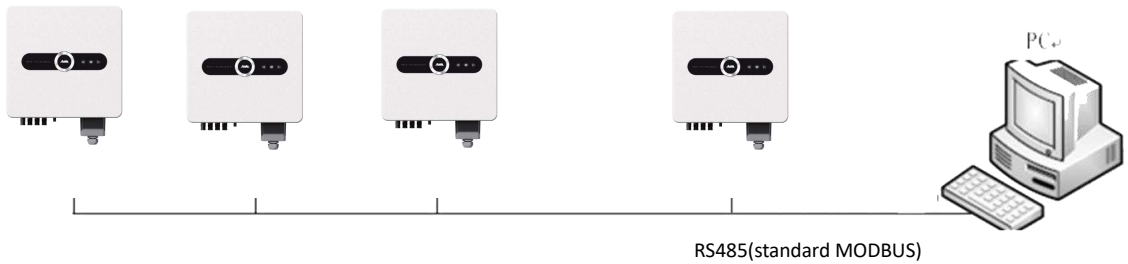

Figure 5-1 RS485 (standard MODBUS protocol) communication system mode

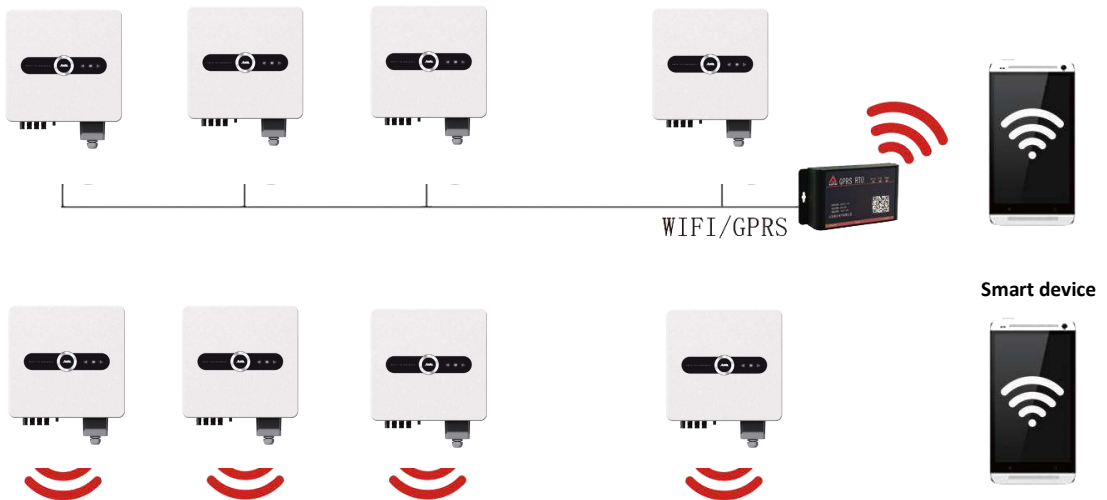
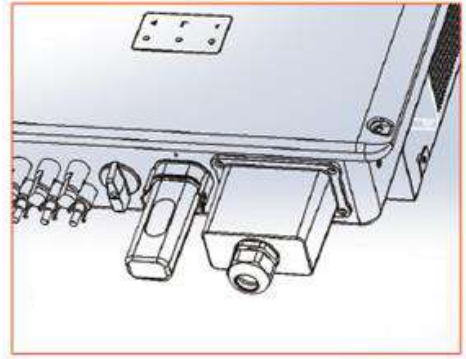
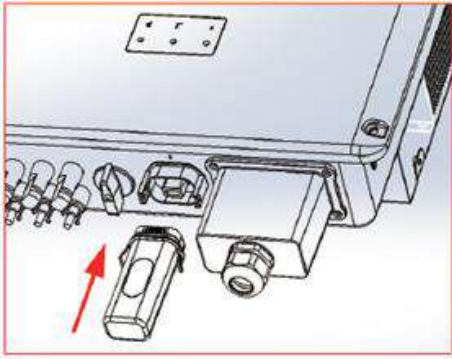

Figure 5-2 WIFI/GPRS communication system mode

After installing the GPRS or Wi-Fi data collector module, you can monitor the operation of the PV system through the AUSTA App program "Ausat Solar" .

- WIFI/GPRS installation



## 5.2 Austa Solar Monitor

Austa Web/Austa Solar APP is rich in functions, covering the entire life cycle of the power station, it perfectly meets the needs of one-stop management. Austa provides installers, operation and maintenance providers, and investors with various tools covering the development period, construction period, and operation and maintenance period of the power station. At the same time, it also provides practical functions such as equipment-based alarm management, protocol management, and control command management for major equipment manufacturers and their distributors.

- Website Login

Web: <http://partner.austasolar.net/>

- Software Installation

Method 1: For ios vesion, earch for "Austa Solar" in the App Store to download and install, and for the Android version, search for "Austa Solar" in the "Google Market" to download and install.

Method 2: Scan the QR code of the icon, enter the download address page, and open the download with a browser.



android



ios

# 6

## Trial run

**Trial run is an important step in the installation of PV systems. Correct trial operation can prevent system fires, electric shocks and other accidents.**

### 6.1 Inspection before trial run

Before turning on the inverter for the first time, you need to do the following inspections.

Environmental inspection

- 1). The installation position of the inverter is convenient for operation and maintenance.
- 2). Reconfirm that the inverter is installed firmly.
- 3). Good ventilation.
- 4). No external objects or parts are left on the top of the inverter.
- 5). The accessories around the inverter are correctly connected.
- 6). Cables are reasonably distributed, well protected and will not be mechanically damaged.
- 7). Reasonable selection of AC circuit breaker.
- 8). The vacant terminal has been sealed.
- 9). All safety signs and warning labels on the inverter are firmly pasted and clearly visible.

### 6.2 Test run steps

If all the above inspections have passed, the inverter can perform the following trial operation steps for the first startup.

- 1) Make sure that the above inspection items meet the requirements.
- 2) The AC side circuit breaker is placed in the "ON" position.
- 3) Rotate the DC switch to the "ON" position.

Assuming sufficient light and power grid conditions meet the conditions:

The PV array is initialized and begins to provide power.

The grid-connected inverter starts to charge the DC bus.

The inverter start generate AC power, and AC power into the power grid.

- 4) Observe the status of the control panel

# 7 Shut down & Dismantle

## 7.1 Shut down

In normal operation, there is no need to shut down the inverter manually, but it is necessary to shut down the inverter during maintenance or repair. To disconnect the inverter from the AC and DC power supply, follow the steps below, otherwise it may cause personal injury or death or equipment damage.

- 1) Disconnect the external AC circuit breaker and prevent reconnection due to mis operation.
- 2) Turn the DC switch to the "OFF" position and unplug all DC string inputs.
- 3) Wait for about 10 minutes until the internal capacitor is discharged.
- 4) At the AC terminal, measure the AC-to-ground voltage to confirm that the AC output voltage of the inverter at the AC circuit breaker is zero.
- 5) Remove the DC connection cable.
- 6) Remove the AC connection cable.



### NOTE

Please strictly follow the above steps, otherwise the inverter will not work normally.

## 7.2 Dismantle the inverter

The user can dismantle the inverter according to the above electrical installation and mechanical installation and follow the reverse steps.

## 7.3 Discarding the inverter

For inverters that will no longer be put into operation in the future, users need to properly dispose of them by themselves. (The control panel, batteries, modules and other components contained in the inverter may pollute the environment. Users need to properly dispose of them in accordance with relevant local laws and regulations.)

# 8

## Operating

### 8.1 Working Mode

The working modes of the inverter include-start mode, run mode, and standby mode. In each working mode, the LCD displays corresponding information.

#### 8.1 .1 Control panel with LCD display

The panel of the TLC series grid-connected PV inverter includes a LCD display. In order to better carry out the interactive operation of the man-machine interface, two LED indicator and a voice switch are set on the panel, as shown in Figure 8-1.

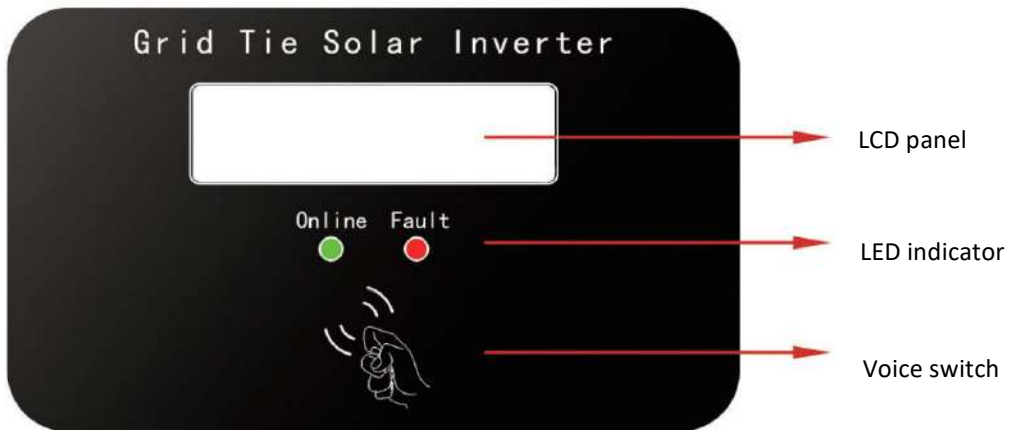



Figure 8-1 AU series LCD control panel

LED display status

No.	LED indicator	Description
1	Online	Grid-connected operation indicator (normal operation, grid-connected power generation indicator is on)
2	Fault	Fault indicator (lights on when a fault occurs)

The use of voice switch

Tap the picture icon  on the panel, the display interface of the LCD panel is switched

#### 8.1.2 Control panel with indicator light only

For the indicator panel of the TLC series grid-connected photovoltaic inverter, in order to better carry out the interactive operation of the man-machine interface, 3 LED lights are set on the panel, as shown in Figure 8-2.



Figure 8-2 AUseries indicator panel

● LED display status

Function	Status		Description
Running	= [	] ~	
			Grid-connected and power generation
			DC is normal, AC is not powered on
			DC is normal, grid-connected standby
			Equipment failure
			DC is not powered on
Communication	Ⓜ		
			The communication cable or communication module is connected, and there is data interaction on the communication channel
			The communication cable or communication module is not connected or there is no data interaction on the communication channel
Light ON		Light OFF	light flashes



**NOTE**

The data in the following tables and graphs are only sample data, and take ASP-8KTLD as an example, the actual display content and data may change

## 8.2 Startup mode

The start mode means that the light conditions meet the DC start conditions of the inverter, but the grid

has not yet been connected to power generation. In this mode, the inverter information is displayed in sequence. After the display is completed, the inverter meets the grid-connected conditions and switches from the startup mode to the running mode, otherwise, it switches to the standby mode.

The screen display sequence of the startup mode is shown in Figure 8-3 (take AU8K1P as an example).

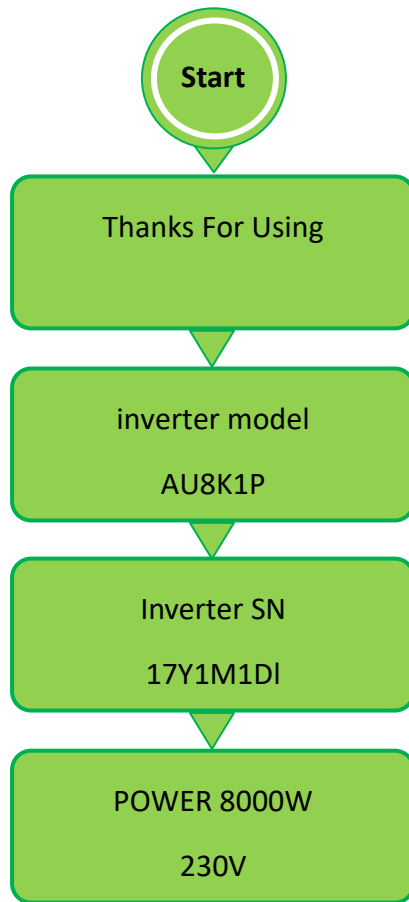

Figure 8-3 Start interface



#### NOTE

After the PV array voltage > 250V, the system will count down for 20 seconds. Within 20 seconds, the PV array voltage will always meet the grid-connected power generation requirements before it will switch to the operation mode.

#### ● Running mode:

In the Running mode, the inverter converts the DC power of the photovoltaic array into AC power and integrates it into the grid. At the same time, the inverter always outputs the maximum energy in the maximum power point tracking (MPPT) mode.



In the running mode, the display content of the LCD liquid crystal display is refreshed every two seconds, so the display content is only valid within the current 2 seconds. The display screen has the default display content. 5 seconds after entering the normal operation state, the LCD displays the default interface, as shown in Figure 8-4.

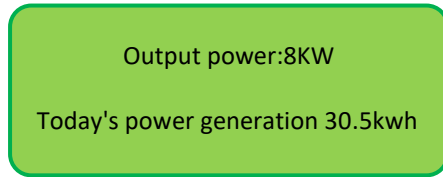

Figure 8-4 Default interface of running mode

In running mode, the screen display content is shown in Table 8-5 and 8-6 (take AU8K1P as an example).

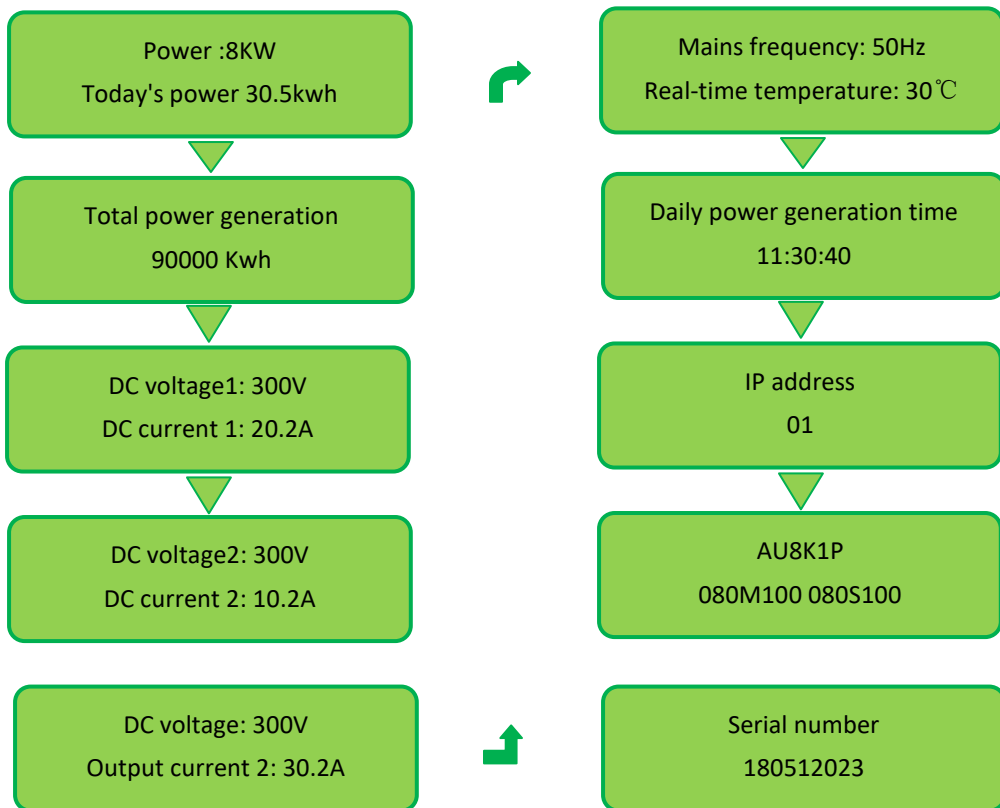

Figure 8-5 Normal interface of running mode

Note: Tap the position of the voice control switch mark, the LCD screen background display light is on, and the switching interface is displayed at the same time, the switching display content is shown in Figure 8-5, no operation within 20 seconds, the background light is off, and the LCD screen returns to the default interface.

 **NOTE**

Tap the voice switch  to switch the content displayed on the LCD



## NOTE

If the DC side cuts off the power supply and is powered on again, the inverter will start to recalculate the total power generation for that day according to the new day.

### ● Standby mode

DC start and the grid connection conditions are not met, it is the standby mode.

In the standby mode, the inverter continuously detects whether the grid-connected power generation conditions are met, and after a 20-second countdown, the inverter switches from the standby mode to the running mode.

In standby mode, the second line of the LCD default interface displays standby information in cycles. The possible standby information is shown in Figure 8-6, one or more of them; tap the front panel to switch to other View detailed information on the interface; in standby mode, the content displayed by screen switching is shown in Figure 8-7 (take AU8K1P as an example)

Standby System abnormal	Standby DC bus voltage is low
Standby DC 1 over current	Standby Phase A over voltage
Standby Hardware protection	Standby Phase A under voltage
Standby AC side overheated	Standby DC 1 under voltage
Standby Neutral point imbalance	Standby Inverter off grid
Standby Phase lock abnormal	Standby Phase B over voltage
Standby DC bus voltage is high	Standby Phase C over voltage

Figure 8-6 Information displayed cyclically in standby mode

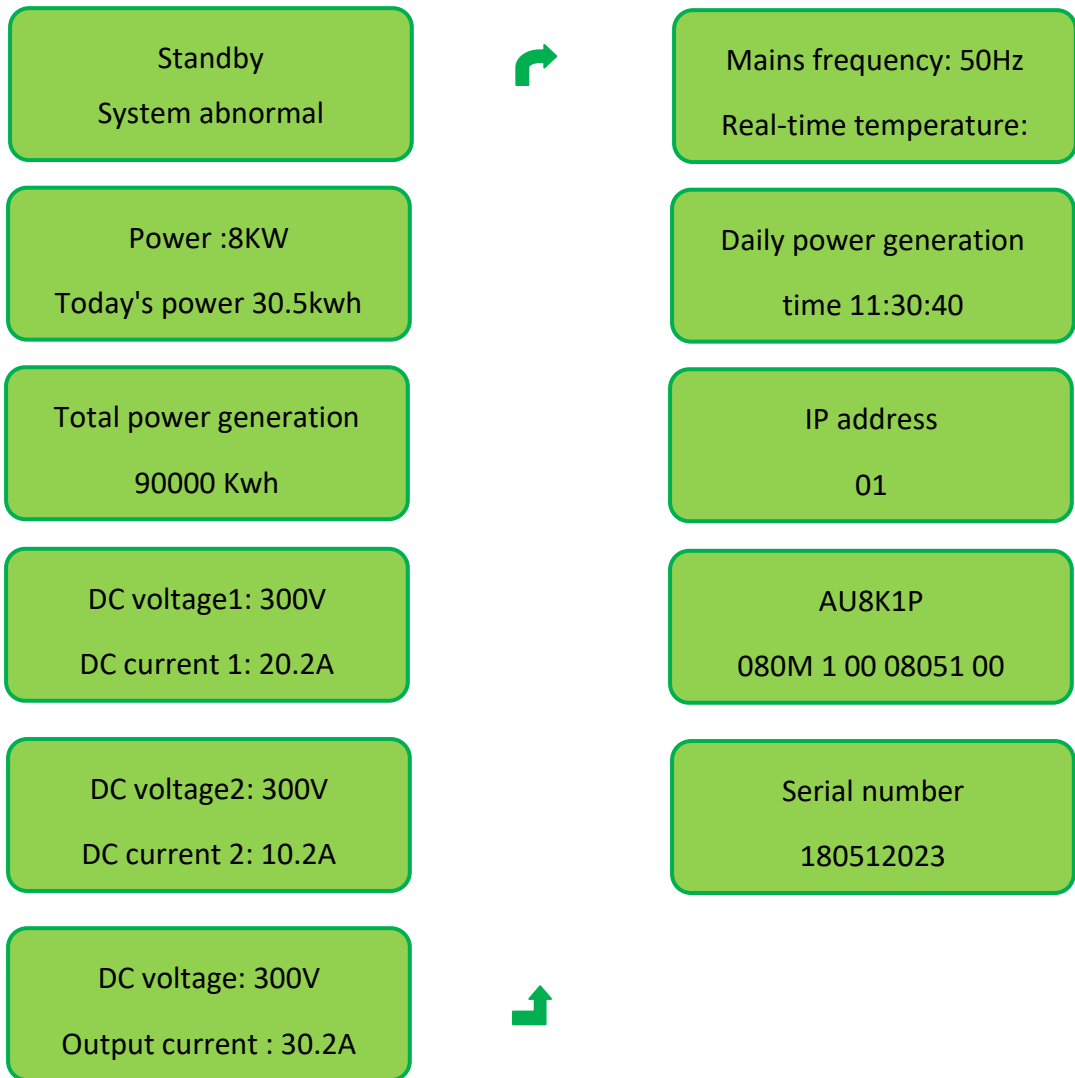

Figure 8-7 Switch display page in standby mode

Note: Tap the position of the voice control switch mark, the LCD screen background display light is on, and the switching interface is displayed at the same time, the switching display content is shown in Figure 8-5, no operation within 20 seconds, the background light is off, and the LCD screen returns to the default interface.



**NOTE**

Tap the voice switch



to switch the content displayed on the LCD

- Switching of working mode

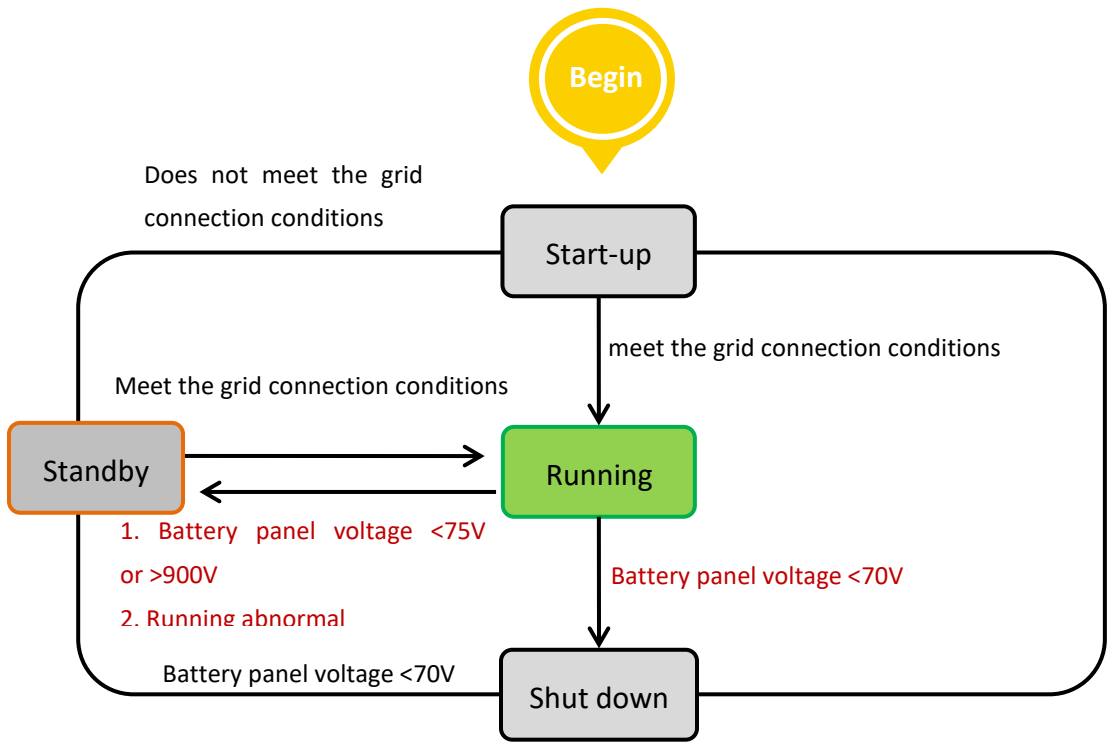

Figure 8-7 Switching of working mode

### 8.3 Power generation process

On grid generating capacity process is automatic, described as follows:

1. Switch on DC and AC circuit breakers, the inverter will enter start-up mode.
2. If input voltage on DC side exceeds 110V, AC side voltage in range 160Vac~270Vac, and grid frequency is normal, inverter begins countdown.
3. The DC side starts after a countdown of 20 seconds;
4. After the DC bus voltage stabilizes, the inverter side starts to work and connects to the grid for power generation.

### 8.4 Disconnect from grid

When the grid has below abnormal situation, inverter will disconnect from the grid immediately.

- The grid voltage is outside the normal range of 160V-270V;
- The grid frequency is outside the normal range of 45-55Hz/55-65Hz;
- The voltage of the photovoltaic array is outside the allowable working range of the inverter;
- The ambient temperature is outside the allowable working range of the inverter.

**DANGEROUS**

Do not open the machine. Users trying to repair the machine by themselves may cause electric shock and fire hazard.

### 9.1 Maintenance

Due to the influence of ambient temperature, humidity, dust and vibration, the internal components of the inverter will age and wear, which will affect the service life of the inverter. Therefore, daily and regular maintenance of the inverter should be carried out to ensure its normal Operation and service life.

- Clean the dust and debris from the radiator frequently.
- When dust accumulates on the photovoltaic array, clean the photovoltaic array with water, and the cleaning should be carried out when the weather is cool.
- Check the system regularly to ensure that all wiring and supply conditions are error-free.
- Always read the information on the LCD display to understand the changes in the inverter's working status.

**WARNING**

Never use a pressure washer to clean the inverter, or other cleaning methods that may cause water to enter the machine.

### 9.2 Troubleshooting

**WARNING**

Only qualified engineers can repair the inverter!

Most errors and malfunctions will be displayed. The following table proposes solutions to several possible problems.

Table.9-1.troubleshooting

No.	Failure	solution
1	LED indicator and LCD screen do not light up	1. Disconnect AC side circuit breaker
		2. Disconnect DC side circuit breaker
		3. Check the input voltage of the PV array (whether it is lower than 90V) and the grid voltage
		4.If the above conditions are met, check the circuit breaker
2	"on line" indicator goes off	1. Disconnect AC side circuit breaker
		2. Disconnect DC side circuit breaker
		3.Check whether the parameters on the AC and DC sides meet the startup requirements. If the parameters meet the requirements, check the wiring according to 4.4 Electrical connection
		3
2. Disconnect DC side circuit breaker		
3. Check whether the voltage of each group of PV array meets the range of 300V-900VDC		
4. When the DC voltage is restored to the allowable range of the inverter, restart the inverter		
4	The grid voltage is abnormal (the grid voltage>270V or <160VAC)	1. Disconnect AC side circuit breaker
		2. Disconnect DC side circuit breaker
		3.Detect the voltage on the AC side
		4.4. If the grid voltage is not within the allowable voltage range of the inverter, please contact the local power company to adjust the grid voltage
5	The grid frequency is abnormal (the grid frequency is neither 45-55Hz nor 55-65Hz)	1. Disconnect AC side circuit breaker
		2. Disconnect DC side circuit breaker
		3.Detect the frequency on the AC side
		4.If the current grid frequency is not in the inverter's allowable frequency range, please contact the local power company to adjust the grid frequency
6	The temperature is too high (inverter temperature is too high)	1. Disconnect AC side circuit breaker
		2. Disconnect DC side circuit breaker
		3. Check whether the ambient temperature is higher than 60 °C or lower than -25 °C

		4. Please check whether the ventilation of the machine is normal, whether the hook-up installation is correct, and whether the air duct is unblocked
		5. Whether the output power exceeds the rated value
7	Abnormal grounding	1. Disconnect AC side circuit breaker
		2. Disconnect DC side circuit breaker
		3. Check whether the ground resistance of each group of PV arrays is greater than 2MΩ

If the fault cannot be solved or your problem is not mentioned in the above table, please contact us.

### 9.3 Quality Assurance

#### ● warranty

The warranty period of this product is subject to the contract.

#### ● Conditions

1. AUSTA will offer free repair service or replace with new product for faults during the warranty.
2. The replaced unqualified product will be returned to AUSTA.
3. Customers need to give AUSTA reasonable time to deal with the machine fault.

#### ● AUSTA will not be liable for the following cases.

1. Transportation damage
2. Improper installation
3. Improper modification
4. Incorrect use
5. Very harsh environment that is beyond the specified in this manual
6. Any installation and use that is beyond the relative international standards
7. Damages caused by improper natural environment

# 10

## Specification

### 10.1 Specification

Technical Data	AU3K1P	AU5K1P	AU6K1P	AU8K1P	AU10K1P
<b>DC Input Data</b>					
Max. DC input power (KW)	4.5	7.5	9	12	15
Max. DC input voltage(VDC)	550				
MPPT voltage range(VDC)	80~550				
Max. DC current(A)	18A	18/18A	18/18A	20/26A	20/30A
Recommended working voltage(VDC)	360V				
MPPT number	1	2			
Max. input strings per MPP tracker	1	1/1		1/2	
<b>AC Output Data</b>					
Normal output Power (KW)	3KW	5KW	6KW	8KW	10KW
Max. AC power (KVA)	3.3KVA	5.5KVA	6KVA	8KVA	10KVA
Normal output current (A)	13.7A	22.7A	27.3A	36.4A	45.5A
Rated power grid voltage(Vac)	230				
Power grid voltage range(Vac)	160~270				
Rated power grid frequency	50Hz/60Hz				
Grid frequency range	45~55Hz/55~65Hz				
THD	<2%(Under the rated power)				
Power factor	>0.99(Under rated power)/Adjustable range 0.8(Leading)~0.8 (Lagging)				
DC component	<0.5%(Under rated power)				
<b>System Data</b>					
Max. Efficiency(%)	98%	98.1%	98.1%	98.1%	98.1%
Euro. efficiency(%)	97.5%	97.5%	97.5%	97.5%	97.6%
Humidity	0~100%, No condensation				
Cooling	Fan				
Allowed ambient temperature range	-25°C ~ +60°C				
Consumption during night	<1W				
Noise	<40dB(When the fan starts <50dB)				



Max. altitude	4000m(It needs to be derated when the altitude exceeds 2000m)		
<b>Mechanical Data</b>			
Size (width x height x depth)	347/368/167		347/368/190
Weight	7	12	11
Protection class	IP66 ( outdoor )		
<b>Display &amp; Communication</b>			
Communication interface	RS485/WIFI(optional)/GPRS(optional)		
Human-machine interface	2 LED indicators, 2 lines of LCD display , acoustic sensing switch		

## 10.2 Quality guarantee

- ✧ The warranty period of this product shall be subject to the contract.
- ✧ condition
- AUSTA will repair or replace the faulty products free of charge during the warranty period.
- Unqualified products after replacement shall be returned to AUSTA.
- The customer shall allow AUSTA a reasonable amount of time to repair faulty equipment.
- ✧ The company reserves the right not to guarantee quality in the following cases:
  - Transport damage.
  - Incorrect installation.
  - Incorrect modification.
  - Incorrect use.
  - Operate beyond the very harsh conditions described in this manual.
  - Any installation and use outside the scope specified in relevant international standards.
  - Damage caused by abnormal natural conditions.

# Feedback Form

Name of Company			
Address			
Contact person		Title	
Telephone No.		Fax No.	
Email Address			
Company' s filed of business			
Comments:			

Thank you for taking time to share your feedback. Your comments and suggestions will help us to serve you better.

Please send fax or e-mail your feedback, we will respond you within 24 hours.

## Contact Information

NINGBO AUSTA SOLAR TECH CO.,LTD.

Tel: +86 574 89137130

Email: [marketing@osdasol.com](mailto:marketing@osdasol.com)

Web:[www.austasolar.net](http://www.austasolar.net)

Add: 1-1 NO.136 Haichuan Road Jiangbei

District Ningbo Zhejiang P.R. China





NINGBO AUSTA SOLAR TECH CO.,LTD.

Tel: +86 574 89137130

Email: [marketing@osdasol.com](mailto:marketing@osdasol.com)

Web: [www.austasolar.net](http://www.austasolar.net)

Add: 1-1 NO.136 Haichuan Road Jiangbei

District Ningbo Zhejiang P.R. China